

## EW-73000

### SERIES

- ▶ **Description**  
 Triple Station Solid Surface Lavatory System Equipped with Sloan OPTIMA® Electronic Sensor Technology.
- ▶ **Model**  
 EW-73000 Three Station SloanStone Lavatory System with Integrated Sloan Optima® Electronic Sensor Technology

- ▶ **Specifications**  
 Triple Station Lavatory System with Sloan Electronic Sensor Technology with the following features:
  - Integrated Head containing pre-plumbed water paths and electronic components allow for rapid, easy installation/maintenance
  - Sloan Optima Electronic Sensors for hands free point of use activation
  - Water Conserving, touch free, on-demand sensors detect users hands at the point of use preventing unintentional activations
  - Recessed sensors are concealed from user, reducing damage and vandalism
  - Dual protected integrated overflows
  - 1½" chrome plated brass drains with grid strainers
  - Optional top filled gravity fed manual Soap Dispensers
  - Basin, Integrated Head and Cabinet End Caps constructed of durable SloanStone solid surface material
  - Concealed Cabinet Frame constructed of heavy duty 16 gauge type 304 stainless steel accented with 18 gauge brushed stainless steel Front Panel
  - No visible fasteners or obvious access points
  - Below deck Thermostatic Mixing Valve, standard
  - ADA and TAS lavatory Rim Height Standards achieved in a single design
  - Aesthetically pleasing soft contoured one-piece continuous Basin
  - Top Access Lid Secured by Ultra Heavy Duty Latch Mechanism with Recessed Allen Key Activation. T-handle Allen wrench standard

**Sloan Optima® Electronics feature:**

- Sloan Optima Sensor Technology for reliable performance
- Troubleshooting LED Indicator Lights
- Solenoid with serviceable Strainer Filter
- Stainless Steel vandal resistant Spouts
- Water saving 0.5 gpm/1.9 Lpm max. Aerator
- Hardwire powered

- ▶ **Variations**  
 **SD** Manual Soap Dispenser  
 **FC** Manual Soap Dispenser with Lid Mounted Fill Cap

- ▶ **Colors**

<input type="checkbox"/> <b>WH</b> White	<input type="checkbox"/> <b>MLG</b> Matrix Light Gray
<input type="checkbox"/> <b>CO</b> Cameo	<input type="checkbox"/> <b>MDG</b> Matrix Dark Gray
<input type="checkbox"/> <b>BO</b> Bone	<input type="checkbox"/> <b>MGR</b> Matrix Green
<input type="checkbox"/> <b>PH</b> Peach	<input type="checkbox"/> <b>MBR</b> Matrix Brown
<input type="checkbox"/> <b>AL</b> Almond	<input type="checkbox"/> <b>MBO</b> Matrix Bone
<input type="checkbox"/> <b>SH</b> Shell	<input type="checkbox"/> <b>MLB</b> Matrix Light Blue
<input type="checkbox"/> <b>PE</b> Pea	<input type="checkbox"/> <b>MSA</b> Matrix Sand
<input type="checkbox"/> <b>BI</b> Biscuit	<input type="checkbox"/> <b>MDB</b> Matrix Dark Blue
<input type="checkbox"/> <b>MWH</b> Matrix White	<input type="checkbox"/> <b>MDU</b> Matrix Dusk
<input type="checkbox"/> <b>MSI</b> Matrix Silver	<input type="checkbox"/> <b>MKH</b> Matrix Khaki
<input type="checkbox"/> <b>MPI</b> Matrix Pink	<input type="checkbox"/> <b>MSU</b> Matrix Summit
<input type="checkbox"/> <b>MJA</b> Matrix Jade	

- ▶ **Warranty**  
 3 year (limited)



**The New SloanStone™ Lavatory System  
 — The Perfect Match**

The dependability of Sloan Optima electronics combined with the durability of our SloanStone solid surface material creates the ultimate in vandal resistant lavatory systems with a unique designer style.

Having all the serviceable components accessible from the top, including a water shut-off valve, all the electronics, sensors, solenoids and soap components, gives SloanStone sinks the simplest installation and maintenance available. All of this is kept secure from prying hands by industrial strength latches utilizing a recessed Allen key engagement mechanism. Therefore, there are no visible fasteners on the unit to invite would-be vandals. The infrared sensors are also recess mounted in a stainless steel plate behind the aerator spray head keeping them out of site of the user, virtually eliminating potential damage to the sensor windows and making this a true water conserving on-demand unit.

A heavy gauge brushed stainless steel front panel conceals the drain lines, supply stops and thermostatic mixing valve; while dual drains with protected overflow outlets complete the exclusive features list that sets SloanStone apart from the competition.



The lavatory system is designed to comply with all applicable ADA, UFAS, Texas Accessibility Standards (T.A.S.), and ANSI Z124.3 and Z124.6 accessibility guidelines when mounted at the recommended rim height.

**Sloan Optima Electronics are:**



Listed by I.A.P.M.O.

This space for Architect/Engineer approval	
Job Name _____	Date _____
Model Specified _____	Quantity _____
Variations Specified _____	
Customer/Wholesaler _____	
Contractor _____	
Architect _____	

The information contained in this document is subject to change without notice.

# EW-73000

## SERIES

### Triple Station Lavatory System

#### OPERATION

As the user's hands enter the beam's effective range, the beam is reflected back into the sensor receiver and activates the solenoid valve allowing water to flow from the spout. Water will flow until user's hands are removed or until the time out limit is reached.

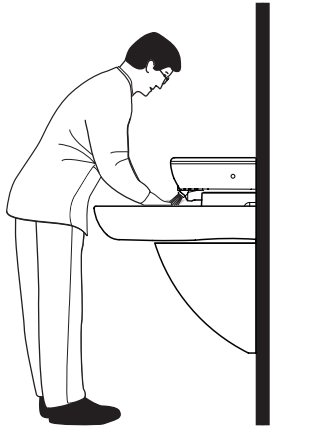

#### SLOANSTONE COLORS

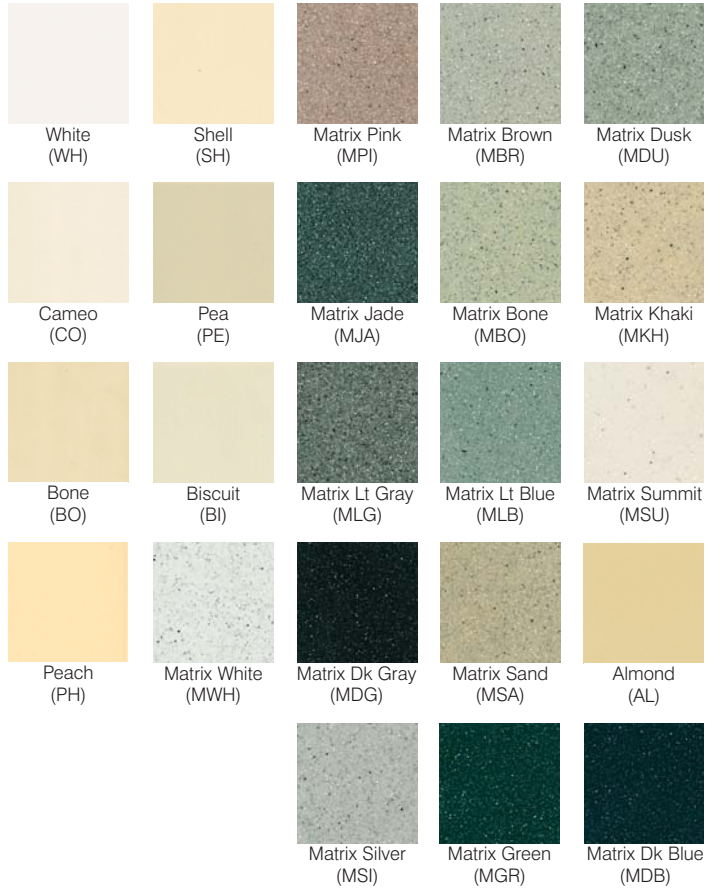

#### ROUGH-IN

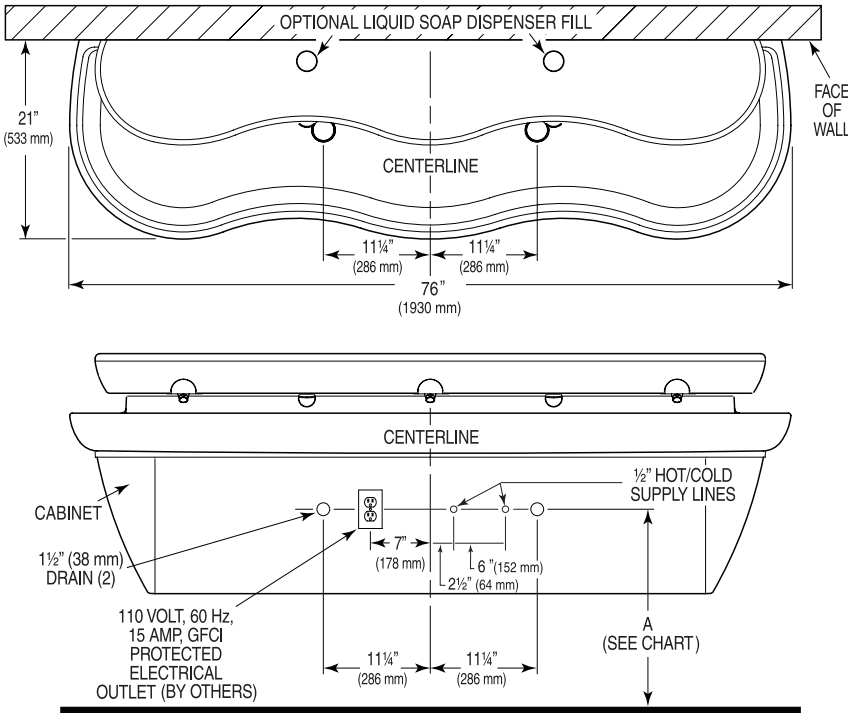

Expanded color options available at: [www.sloanstonesinks.com](http://www.sloanstonesinks.com).

For in stock availability and quick-ship options please contact your local Sloan representative.

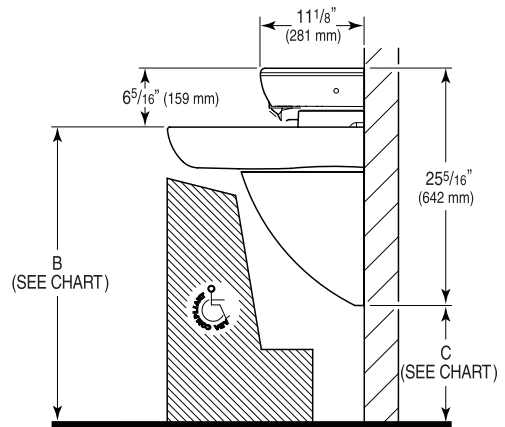

† When no mirror is required above the basin.  
For T.A.S. compliant installations requiring a mirror above the basin, use ELS-73000 products.

Consult local electrical codes for the mounting location of the 110/24 VAC Class 2 transformer.

For additional technical information, contact the Sloan Installation Engineering Department at 1-888-SLOAN-14 (1-888-756-2614) or [techsupport@sloanvalve.com](mailto:techsupport@sloanvalve.com).

VARIABLE MOUNTING HEIGHT CHART			
DIMENSION DESCRIPTION	T.A.S. † AGES 4-10	T.A.S. † AGES 11-15	A.D.A. STANDARD
A ROUGH-IN	20-1/2" (521 mm)	22-1/2" (572 mm)	24" (610 mm)
B RECOMMENDED RIM HEIGHT	29-7/8" (759 mm)	31-7/8" (810 mm)	33 (838 mm)
C FLOOR CLEARANCE	10-7/8" (276 mm)	12-7/8" (327 mm)	14" (356 mm)

**SLOAN VALVE COMPANY • 10500 SEYMOUR AVENUE • FRANKLIN PARK, IL 60131**

Phone: 1-800-982-5839 or 1-847-671-4300 • Fax: 1-800-447-8329 or 1-847-671-4380 • [www.sloanvalve.com](http://www.sloanvalve.com)